

EN

OPERATING MANUAL
PARTICLE MEASURING DEVICE



Table of contents

Notes regarding the operating manual..... 2

Safety 2

Information about the device..... 4

Transport and storage..... 7

Operation 7

Maintenance and repair 9

Errors and faults..... 10

Disposal 10

Notes regarding the operating manual

Symbols

 **Warning of electrical voltage**
This symbol indicates dangers to the life and health of persons due to electrical voltage.

 **Warning of explosive substances**
This symbol indicates dangers to the life and health of persons due to potentially explosive substances.

 **Warning of laser radiation**
This symbol indicates dangers to the health of persons due to laser radiation.

 **Warning**
This signal word indicates a hazard with an average risk level which, if not avoided, can result in serious injury or death.

 **Caution**
This signal word indicates a hazard with a low risk level which, if not avoided, can result in minor or moderate injury.

Note
This signal word indicates important information (e.g. material damage), but does not indicate hazards.

 **Info**
Information marked with this symbol helps you to carry out your tasks quickly and safely.

 **Follow the manual**
Information marked with this symbol indicates that the operating manual must be observed.

You can download the current version of the operating manual and the EU declaration of conformity via the following link:



BQ30



<https://hub.trotec.com/?id=42166>

Safety

Read this manual carefully before starting or using the device. Always store the manual in the immediate vicinity of the device or its site of use.

-  **Warning**
Read all safety warnings and all instructions. Failure to follow the warnings and instructions may result in electric shock, fire and/or serious injury. **Save all warnings and instructions for future reference.**
This appliance can be used by children aged from 8 years and above and persons with reduced physical, sensory or mental capabilities or lack of experience and knowledge if they have been given supervision or instruction concerning use of the appliance in a safe way and understand the hazards involved. Children shall not play with the appliance. Cleaning and user maintenance shall not be made by children without supervision.
- Do not use the device in potentially explosive rooms or areas and do not install it there.
 - Do not use the device in aggressive atmosphere.
 - Do not immerse the device in water. Do not allow liquids to penetrate into the device.
 - The device may only be used in dry surroundings and must not be used in the rain or at a relative humidity exceeding the operating conditions.
 - Protect the device from permanent direct sunlight.
 - Do not remove any safety signs, stickers or labels from the device. Keep all safety signs, stickers and labels in legible condition.
 - Do not open the device.
 - Avoid looking directly into the laser beam.
 - Never point the laser beam at people or animals.

- Only use the device, if sufficient safety precautions were taken at the surveyed location (e.g. when performing measurements along public roads, on building sites etc.). Otherwise do not use the device.
- Observe the storage and operating conditions as given in the Technical data chapter.

Intended use

The device is intended for measuring the size and number as well as the mass concentration of particles in the air.

To use the device for its intended use, only use accessories and spare parts which have been approved by Trotec.

Improper use

The device may not be used for measurements in liquids.

The device may not be used in potentially explosive atmospheres, when wet or very humid.

Any unauthorised changes, modifications or alterations to the device are forbidden.

Personnel qualifications

People who use this device must:

- have read and understood the operating manual, especially the Safety chapter.

Residual risks



Warning of electrical voltage

There is a risk of a short-circuit due to liquids penetrating the housing!

Do not immerse the device and the accessories in water. Make sure that no water or other liquids can enter the housing.



Warning of electrical voltage

Work on the electrical components must only be carried out by an authorised specialist company!



Warning of electrical voltage

Before any work on the device, remove the mains plug from the mains socket and the battery from the device! Hold onto the mains plug while pulling the power cable out of the mains socket.



Warning of explosive substances

Do not expose the battery to temperatures above 45 °C! Do not let the battery come into contact with water or fire! Avoid direct sunlight and moisture. There is a risk of explosion!



Warning of laser radiation

Laser class 2, P max.: < 1 mW, λ: 400-700 nm, EN 60825-1:2014

Do not look directly into the laser beam or the opening from which it emerges.

Never point the laser beam at people, animals or reflective surfaces. Even brief eye contact can lead to eye damage.

Examining the laser output aperture by use of optical instruments

(e.g. magnifying glass, magnifiers and the like) entails the risk of eye damage.

When working with a laser of class 2, observe the national regulations on wearing eye protection.



Warning of laser radiation

Laser class 1

The laser is encapsulated.

Do not open the device to prevent direct contact with the laser and the emitted radiation!



Warning

Risk of suffocation!

Do not leave the packaging lying around. Children may use it as a dangerous toy.



Warning

The device is not a toy and does not belong in the hands of children.



Warning

Dangers can occur at the device when it is used by untrained people in an unprofessional or improper way! Observe the personnel qualifications!



Caution

Lithium-ion batteries might catch fire in case of overheating or damage. Ensure a sufficient distance to heat sources, do not subject lithium-ion batteries to direct sunlight and make sure not to damage the casing. Do not overcharge lithium-ion batteries. Only use smart chargers that switch off automatically when the battery is fully charged. Charge lithium-ion batteries in due time before they are discharged completely.



Caution

Keep a sufficient distance from heat sources.

Note

To prevent damages to the device, do not expose it to extreme temperatures, extreme humidity or moisture.

Note

Do not use abrasive cleaners or solvents to clean the device.

Information about the device

Device description

The air quality monitor serves to detect the mass concentration of the particle fractions PM2.5 and PM10 as well as the CO₂ concentration and to measure important climate data such as the relative humidity and temperature of the air.

Nowadays we humans are almost permanently subjected to an increased particulate matter pollution – be it near heavily frequented roads, industrial areas or even in living areas. But over time the concentration of the CO₂ content also increases noticeably – particularly in closed or poorly ventilated living spaces and buildings and with reference to the number of persons located there.

Ordinary things and tasks such as cooking, vacuuming, candle or tobacco smoke can be the source of emissions – just like the emissions from heat sources (e.g. stoves and fireplaces) – and as such have a direct negative effect on the indoor climate and consequently the well-being. For an increased concentration of fine particulates and CO₂ in the air can not only affect the overall well-being, but also be responsible for difficulties in concentrating and insomnia as well as for various allergic reactions. On a long-term basis, the exposure to fine particulates increases the risk of developing cardiovascular and respiratory diseases, even pulmonary cancer.

Fundamentally, a distinction is made between the two particle fractions PM10 and PM2.5 for measuring. PM10 includes all particles with a maximum diameter of 10 µm and PM2.5 means all particles with a diameter of less than 2.5 µm. These particles are invisible to the naked eye. As small as they are – especially the particles of the size PM2.5 – they can reach the pulmonary alveoli. Yet more minute particles of less than 1 µm can even reach blood vessels.

To detect the data, the particle measuring device sucks in air for an adjustable amount of time and determines the mass concentration of the contained particles.

Particles sized 2.5 µm and 10.0 µm are treated equally during this process.

The detected values for all active particle sizes are simultaneously displayed on a colour display. Additionally, the air contamination is indicated on a colour scale. With respect to the mass concentration of particle size PM2.5 you can define limit values preset in the device which, when exceeded, trigger an acoustic alarm signal. Additionally, a six-level colour display indicating the respective alarm levels helps you to quickly assess the current state of the particle concentration ranging between good and highly critical (see table Alarm limit values for particle concentration).

The device is equipped with an integrated measuring cell with laser (class 3R laser, 780 nm, 1.5-3 mW). Owing to the tamper-proof enclosure it is classified as laser class 1 (DIN EN 60825-1) according to the Technical Regulations of the Occupational Health and Safety Ordinance on Artificial Optical Radiation (TROS) devised by the German Federal Institute for Occupational Health and Safety. Maintenance and repair work may only be carried out by trained expert staff observing the legal regulations.

Alarm limit values for particle concentration PM2.5

Air quality	Value in µg/m ³	Indicator scale
Good	0 to 35 µg/m ³	Green
Normal	35 to 75 µg/m ³	Yellow
Low contamination	75 to 150 µg/m ³	Orange
Moderate contamination	150 to 200 µg/m ³	Red
High contamination	200 to 250 µg/m ³	Purple
Severe contamination	> 250 µg/m ³	Dark purple

Alarm limit values for particle concentration PM10

Air quality	Value in µg/m ³	Indicator scale
Good	0 to 75 µg/m ³	Green
Normal	75 to 150 µg/m ³	Yellow
Low contamination	150 to 300 µg/m ³	Orange
Moderate contamination	300 to 400 µg/m ³	Red
High contamination	400 to 500 µg/m ³	Purple
Severe contamination	> 500 µg/m ³	Dark purple

Alarm limit values for CO₂ concentration

Air quality	CO ₂ value in ppm	Indicator colour measured result ¹
Good	0 to 800 ppm	Green
Normal	800 to 1500 ppm	Orange
Poor	1500 to 9999 ppm	Red

¹ In the CO₂ measuring mode the measured results is indicated in the respective indicator colour.

Device depiction

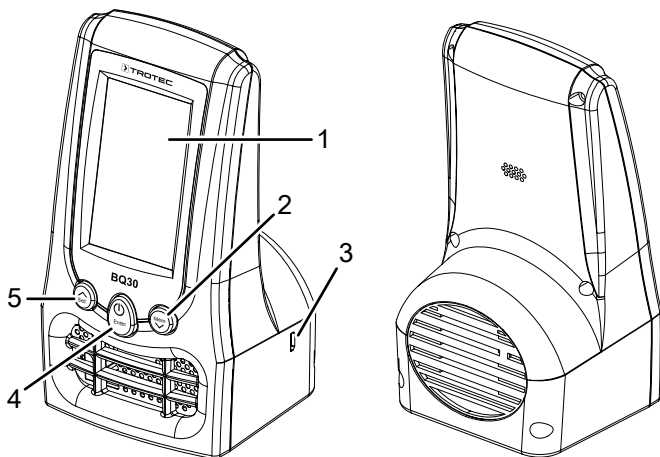

No.	Designation
1	Display
2	MEM / button
3	Charging cable connection
4	Power / ENTER button
5	SET / button

Display

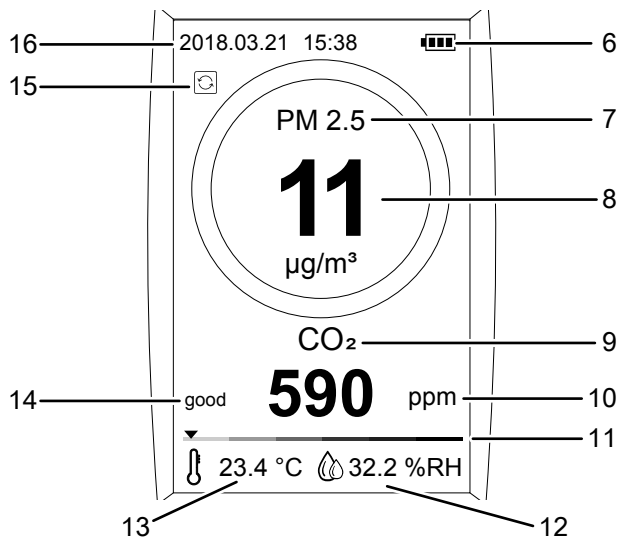

No.	Designation	Meaning
6	Battery indicator	Indicates the battery level / charging status.
7	Particle size PM2.5	Device measures the mass concentration of particles sized up to max. 2.5 μm .
8	Mass concentration of particles	Measured particle mass concentration in $\mu\text{g}/\text{m}^3$
9	Measuring mode CO ₂ /PM10	CO ₂ : Carbon dioxide concentration in ppm PM10: Device measures the mass concentration of particles sized up to max. 10 μm .
10	Measurement unit ppm or $\mu\text{g}/\text{m}^3$	
11	Indicator scale for particle contamination	Colour indicator for the degree of particle contamination (For an explanation of the colours please refer to chapter Operation.)
12	Measured relative humidity value	
13	Measured ambient temperature value	
14	Air quality assessment	Levels: good, normal, poor
15	Measurement status	: Device performs particle measurement (interval between measurements can be set in minutes: 5, 10, 15, 30, 60, OFF). If the measurement interval is set to OFF, the device performs a non-stop particle measurement. : Device is presently not performing a particle measurement. Regardless of the status of the particle measurement the device permanently measures relative humidity, ambient temperature and carbon dioxide concentration.
16	Date and time	Date format: YYYY.MM.DD Time format: 12 h or 24 h

Technical data

Parameter	Value
Model	BQ30
Dimensions (length x width x height)	85 mm x 75 mm x 155 mm
Weight	360 g
Interfaces	USB port for charger
Operating temperature	0 °C to 50 °C
Storage temperature	-10 °C to 60 °C
Display	3 inch TFT LCD, 240 x 400 pixels
Data storage	5,000 data records on internal memory (ring memory)
Energy	
Battery	Li-ion
Nominal voltage	3.7 V ---
Capacity	2400 mAh
Operating time	approx. 5 hours of continuous operation
Charging	5 V / 1 A
Charging time	approx. 2 hours with the device switched off
Automatic switch-off	10 to 120 min (in increments of 10 minutes)
Mass concentration of particles	
Mass concentration channels (detectable particle sizes)	PM2.5 / PM10 (2.5 μm / 10.0 μm)
Mass concentration measuring range	0 to 2000 $\mu\text{g}/\text{m}^3$
Mass concentration resolution	1 $\mu\text{g}/\text{m}^3$
Light source of the measuring cell	Laser class 1 (class 3R laser enclosed in a way to prevent tampering, 780 nm, 1.5-3 mW, classified according to DIN EN 60285-1 and the Technical Regulations of the Occupational Health and Safety Ordinance on Artificial Optical Radiation (TROS))
CO₂ concentration	
CO ₂ concentration measuring range	0 to 9999 ppm
CO ₂ concentration accuracy	$\pm 5\%$ / ± 75 ppm
CO ₂ concentration resolution	1 ppm

Parameter	Value
Temperature measurement	
Temperature measuring range	-20 °C to 70 °C (-4 °F to 158 °F)
Temperature accuracy	± 2 °C
Temperature resolution	0.1 °C
Humidity measurement	
Humidity level measuring range	0 % RH to 100 % RH
Humidity level accuracy	± 3.5 % RH at 20 % to 80 % RH ± 5 % RH at 0 % to 20 % RH and 80 % to 100 % RH
Humidity level resolution	0.1 % RH

Scope of delivery

- 1 x Particle measuring device BQ30
- 1 x USB connecting cable
- 1 x Li-ion battery
- 1 x Manual

Transport and storage

Note

If you store or transport the device improperly, the device may be damaged.

Note the information regarding transport and storage of the device.

Transport

For transporting the device, use the bag included in the scope of delivery in order to protect the device from external influences.

The supplied Li-ion batteries are subjects to the requirements of dangerous goods legislation.

Observe the following when transporting or shipping Li-ion batteries:

- The user may transport the batteries by road without any additional requirements.
- If transport is carried out by third parties (e.g. air transport or forwarding company), special requirements as to packaging and labelling must be observed. This includes consulting a dangerous goods specialist when preparing the package.
 - Only ship batteries if their housing is undamaged.
 - Mask open terminals with tape and pack the battery in a way that it cannot move inside the packaging.
 - Please also observe any other national regulations.

Storage

When the device is not being used, observe the following storage conditions:

- dry and protected from frost and heat
- protected from dust and direct sunlight
- with a cover to protect it from invasive dust if necessary
- The storage temperature is the same as the range given in the Technical data chapter.
- When storing the device for an extended period of time, remove the battery/batteries.

Operation

Charging the battery

The battery is partially charged upon delivery to avoid damage to the battery caused by a deep discharge.



Warning of electrical voltage

Before each use of the charger or power cable, check for damages. If you notice damages, stop using the charger or power cable!

Note

The battery can be damaged in case of improper charging.

Remove the charger's mains plug before inserting or removing the battery.

Never charge the battery at ambient temperatures below 10 °C or above 40 °C.

The battery should be charged prior to initial start-up and when the battery is low (battery indicator (6) flashes). To do so, please proceed as follows:

1. Plug the charger into a properly fused mains socket.
2. Connect the charging cable to the device's USB connection.

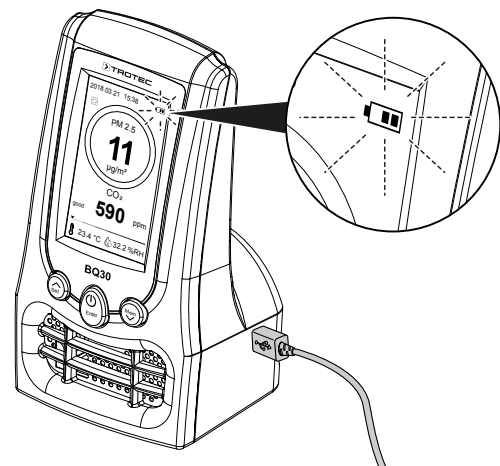

- ⇒ The device switches on automatically as you connect the charging cable and a charging indicator will appear on the display.

Switch-on

1. If the device is switched off, press and hold the power button (4) until the colour display turns on.
 - ⇒ An acoustic signal is emitted.
 - ⇒ The device is ready for operation as soon as the start screen is displayed.

Carrying out a measurement



Info

Please note that moving from a cold area to a warm area can lead to condensation forming on the device's circuit board. This physical and unavoidable effect can falsify the measurement. In this case, the display shows either no measured values or they are incorrect. Wait a few minutes until the device has become adjusted to the changed conditions before carrying out a measurement.

Once you have switched the device on, it automatically performs the measurement. You can tell whether the device is currently performing a measurement from the indicated measurement status (15) on the display.

In addition to the displayed measurement results an indicator scale for particle contamination (11) further helps you in judging the measured results (see chapter Information about the device for more details). When measuring the CO₂ concentration the device displays the measured result in one of the following colours:

Air quality	CO ₂ value in ppm	Indicator colour measured result ¹
Good	0 to 800 ppm	Green
Normal	800 to 1500 ppm	Orange
Poor	1500 to 9999 ppm	Red

System settings

The following submenus offering further setting options can be accessed from the system settings' main menu:

Submenu	Function
Date & Time	Setting the date and time
Auto OFF	Setting the automatic switch-off
Unit	Changing the temperature unit
Alarm	Configuring and enabling/disabling the alarm
Brightness	Setting the screen brightness
Storage rate	Setting the time intervals between particle measurements
Language	Setting the menu language of the device
Info	Calling up software information

1. Press the *SET/* button (5) for approx. 2 s to open the system settings' main menu.
2. Press the *SET/* (5) or the *MEM/* button (2) to select a submenu.

Setting the date and time

You can set the date and time and select whether to display the time in 24 h or 12 h format. To do so, please proceed as follows:

1. Open the submenu Date & Time.
2. Press the *MEM/* button (2) to set the desired time format.
3. Press the *ENTER* button (4) once to set date and time.
4. You can now set year, month, day, hour and minutes one by one.
 - ⇒ Use the buttons (5) and (2) to select the desired value. Confirm each of the entered values by pressing the *ENTER* button (4).

Setting the automatic switch-off

The automatic switch-off can be adjusted in increments of 10 min within the range of 10 to 120 minutes. You can also deactivate the automatic switch-off function by selecting the value OFF. To do so, please proceed as follows:

1. Open the submenu Auto OFF.
 - ⇒ Use the buttons (5) and (2) to select the desired value. Confirm the entered value by pressing the *ENTER* button (4).

Changing the temperature unit

You can select whether the temperature is to be displayed in °C or °F. To do so, please proceed as follows:

1. Open the submenu Unit.
 - ⇒ Use the buttons (5) and (2) to select the desired value. Confirm the entered value by pressing the *ENTER* button (4).

Configuring and enabling/disabling the alarm

For the measurement of particles of 2.5 µm size a limit value that triggers an alarm can be defined at the device. You can choose from the following values: 10 µg/m³, 35 µg/m³, 75 µg/m³, 150 µg/m³ and 200 µg/m³. The setting "No alarm" deactivates the alarm. Please proceed as follows to adjust the alarm settings:

1. Open the submenu Alarm.
 - ⇒ Use the buttons (5) and (2) to select the desired value. Confirm the entered value by pressing the *ENTER* button (4).

Setting the screen brightness

It is possible to adjust the screen brightness. To do so, please proceed as follows:

1. Open the submenu Brightness.
 - ⇒ Use the buttons (5) and (2) to set the desired brightness level. Confirm the entered value by pressing the *ENTER* button (4).

Setting the time intervals between particle measurements

You can set the time intervals in which the device shall perform the individual particle measurements. The measurements of relative humidity, ambient temperature and carbon dioxide concentration remain unaffected by this setting; they are measured permanently by the device.

You can choose from the following particle measurement intervals: 5, 10, 15, 30 and 60 minutes. If you select the value OFF, the device performs a non-stop particle measurement.

Please proceed as follows:

1. Open the submenu Storage rate.
 - ⇒ Use the buttons (5) and (2) to set the desired time interval between measurements. Confirm the entered value by pressing the *ENTER* button (4).

Setting the menu language of the device

You can set the menu language of the device. You can choose from the following languages: German, English, French, Italian, Dutch, Spanish, Polish and Turkish. To do so, please proceed as follows:

1. Open the submenu Language.
 - ⇒ Use the buttons (5) and (2) to select the desired language. Confirm the entered value by pressing the *ENTER* button (4).

Calling up software information

Please proceed as follows to view your software version and the IMEI number of your device.

1. Open the submenu Info.
 - ⇒ Both the software version and the IMEI number will be indicated on the display (1).

Displaying the memory use

Up to 5,000 data records can be stored on the device's internal ring memory. The measurement results are automatically saved on the device. When exceeding the maximum number of data records, the respectively oldest data records will be overwritten.

Please proceed as follows to have the saved values displayed by the device:

1. Press the *MEM* button for approx. 2 s to open the Memory menu.
 - ⇒ The last eight measurement results are dynamically displayed in form of a line graph.
2. Briefly press the *ENTER* button (4) to display individual saved measurement results.
 - ⇒ Date, time and memory slot of the currently selected measurement result will be indicated on the display (1).
 - ⇒ The measured result is additionally displayed as a line graph.
3. Using the buttons (5) and (2) you can browse the list of saved measurement results.
4. Again press the *MEM* button for approx. 2 s to exit the Memory menu.

Switch-off

1. Press and hold the power button (4) until the display (1) turns off.
 - ⇒ An acoustic signal is emitted.
 - ⇒ The device has switched itself off.

Maintenance and repair



Warning of laser radiation



Laser class 1

The laser is encapsulated.

Do not open the device to prevent direct contact with the laser and the emitted radiation!

Charging the battery

The battery should be charged if the battery indicator (6) on the device flashes or if the device can no longer be switched on (see chapter Charging the battery).

Cleaning

Clean the device with a soft, damp and lint-free cloth. Make sure that no moisture enters the housing. Do not use any sprays, solvents, alcohol-based cleaning agents or abrasive cleaners, but only clean water to moisten the cloth.

Repair

Do not modify the device or install any spare parts. For repairs or device testing, contact the manufacturer.

Errors and faults

The device has been checked for proper functioning several times during production. If malfunctions occur nonetheless, check the device according to the following list.

Display segments are only faintly visible or flicker:

- The battery capacity is too low. Recharge the battery without delay.

The device unexpectedly indicates an abnormally high or inexplicable particle concentration at different locations in the room:

- Check whether the device has been exposed to strong sunlight or concentrated light from other (possibly artificial) sources. This can affect the optical sensor and cause a malfunction. For this reason, do not position the device in exposed locations (e.g. on window sills).
- Switch the device off and restart it.
- If the device continues to indicate high values, use another, comparable device (if possible) and check whether it indicates a similar particle concentration.
 - If the reference device, too, indicates abnormally high values, it can be assumed that the particle concentration is indeed significantly increased.
 - If the reference device indicates a significantly lower or negligible particle concentration while the affected device continues to indicate excessive values after another restart, the affected device must be repaired/inspected.

For repairs or device testing, contact the manufacturer.

Disposal



The icon with the crossed-out waste bin on waste electrical or electronic equipment stipulates that this equipment must not be disposed of with the household waste at the end of its life. You will find collection points for free return of waste electrical and electronic equipment in your vicinity. The addresses can be obtained from your municipality or local administration. For further return options provided by us please refer to our website <https://de.trotec.com/shop/>.

The separate collection of waste electrical and electronic equipment aims to enable the re-use, recycling and other forms of recovery of waste equipment as well as to prevent negative effects for the environment and human health caused by the disposal of hazardous substances potentially contained in the equipment.



In the European Union, batteries and accumulators must not be treated as domestic waste, but must be disposed of professionally in accordance with Directive 2006/66/EC of the European Parliament and of the Council of 6 September 2006 on batteries and accumulators. Please dispose of batteries and accumulators according to the relevant legal requirements.

Trotec GmbH

Grebbener Str. 7
D-52525 Heinsberg

☎ +49 2452 962-400

☎ +49 2452 962-200

✉ info@trotec.com

www.trotec.com